

Nero[®]

Nero 7G Ozone Machine

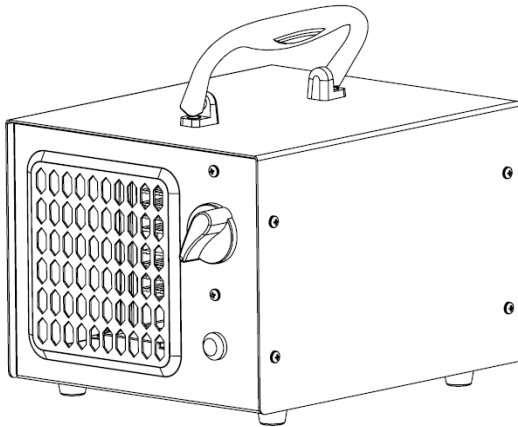

Product Code: 350078

OWNER'S MANUAL

Please read all of the information provided in this owner's manual before operating the new Nero 7G Ozone Machine.

Images in this manual are for illustrative purposes only.

Due to constant improvements, we advise that changes to the design, material, specifications and product configuration may occur at any time without notice.

Index

3. Warnings

4. Specifications

5. Functions front view

6. Functions rear view



7. Operation

8. Maintenance

9. Troubleshooting

WARNING

This air unit is not a medical device. Do not stop or alter any medical therapy programs or medications without the advice of your physician. Excessive ozone concentrations may cause mucous membrane or respiratory irritation.

	CAUTION	
	RISK OF ELECTRICAL SHOCK DO NOT OPEN	
	ATTENTION	

CAUTION: TO REDUCE THE RISK OF ELECTRICAL SHOCK, DO NOT REMOVE COVER. NO USER SERVICEABLE PARTS INSIDE. REFER SERVICING TO QUALIFIED SERVICE PERSONNEL.

This “bolt of lightning” indicates that uninsulated material within your unit may cause an electrical shock. For the safety of everyone, do not remove product covering.

INTRODUCTION

The Nero 7G Ozone Machine is an advanced and convenient contaminant remediation product. High-powered oxidation in a compact, lightweight, rugged and replugable ozone module design. Utilizing controlled corona discharge ozone technology developed specifically to reduce odors and smoke in unoccupied spaces, ideal for hospitality and office use and more!

SPECIFICATIONS

Model:	350078
Rated Voltage:	Europe AC 220-240V/50-60Hz USA/Japan AC 100-120V/50-60Hz
Power Consumption:	85W
Ceramic Plate Size(2 plates):	95X70MM
Air Volume:	Max 106CFM(3 M ³ /min)
Active Oxygen(on) :	7.0 g/h
Sound Level(DB):	40 Db
Product size(mm):	W220xH170xD160MM
Weight:	2.9Kgs(6.38Lbs)

Operating the Nero 7G Ozone Machine

(Front View)

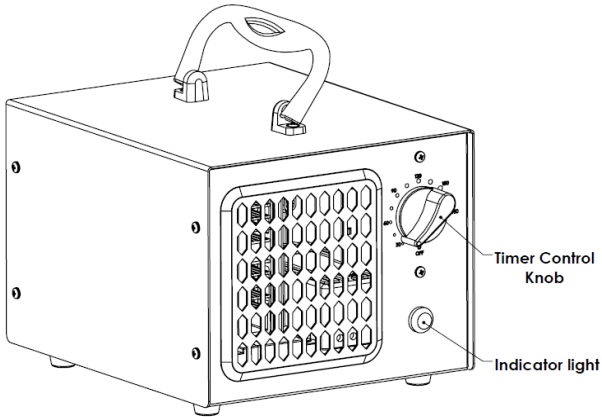

PART

FUNCTION

Timer Control Knob

Turn clockwise to set the timer for timed operation up to THREE hours.

Indicator Light

Illuminates when unit is in operation.

(Back View)

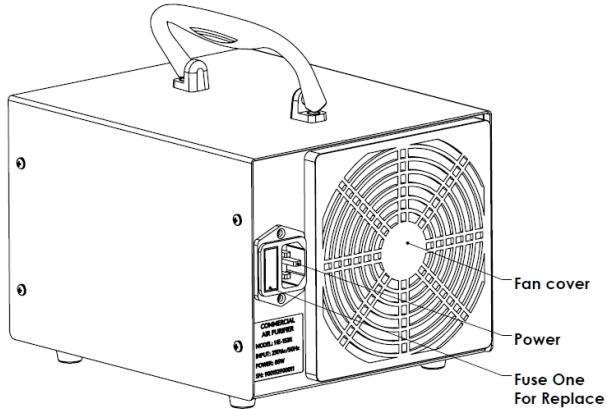

PART

FUNCTION

Fuse Holder

Houses removable fuse.

(Spare fuse included, 2 amp, 0.79
inch in length)

Power Cord

220~240 Volt grounded cord

OPERATION

The Nero 7G Ozone Machine is designed to remove odors in unoccupied spaces. The unit has a timer that will enable it to run for a maximum duration of 3 hours. The timer will then shut the air purifier off. You should allow 40 minutes before returning to the treated area.

To operate the Nero 7G Ozone Machine:

- Close off the desired area to be treated.
- Remove all occupants and pets.
- Position the unit as close as possible to the odor source.
- In such environments as motels that have individual heating and cooling systems, turn the fan on and set on re-circulate.
- Set timer to desired time and leave the room.
- Allow 40 minutes before re-entering the treated space.
- Return to space & ventilation area.

MAINTENANCE

When the Nero 7G Ozone Machine no longer produces enough ozone to be effective, the ozone plates should be replaced. (Usually they should be replaced after 6000 hours)

How to replace the ozone plate:

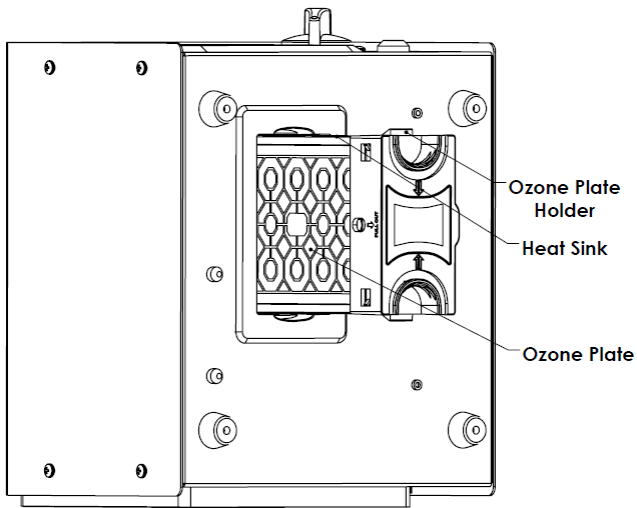

- Turn off the local power supply.
 - Pull out the ozone plate module directly by hand.
 - Install new ozone plate module
- (Be careful not to drop the plate module)

TROUBLESHOOTING

If you suspect a problem with your unit check the following:

- 1) Unit is plugged in properly.
- 2) It's important that the Nero 7G Ozone Machine be properly grounded to avoid potential shock.
- 3) Fuse is installed properly and in good condition. To replace fuse, pull out the plastic fuse holder, remove old fuse and insert new fuse. Replacement fuse must be 2 amp (0.79 inch). Refer to picture as follows:



SERVICE AND WARRANTY

Backed by the Nero 1 Year Warranty

Imported By:
R Weatherdon & Co Pty Ltd

www.weatherdon.com.au

Made in China